

1	2	3	4	5	6	7	8	9

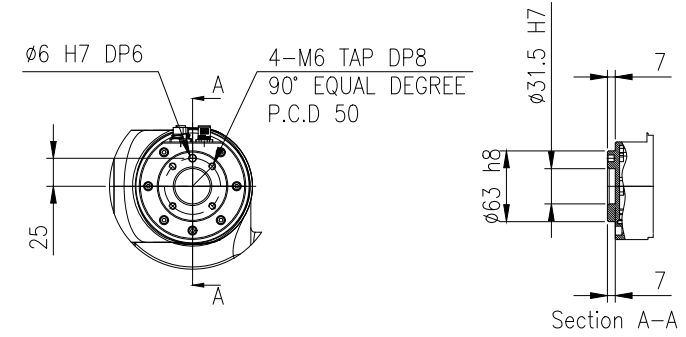

Detail A (TOOL FLANGE)
(Scale 1/5)

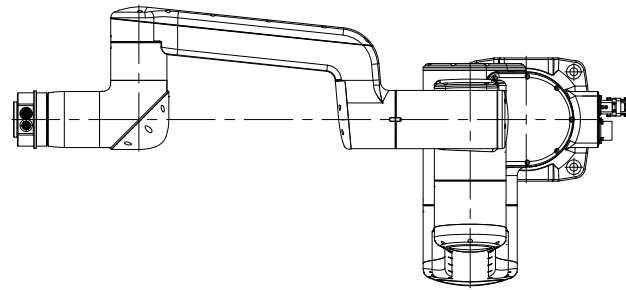
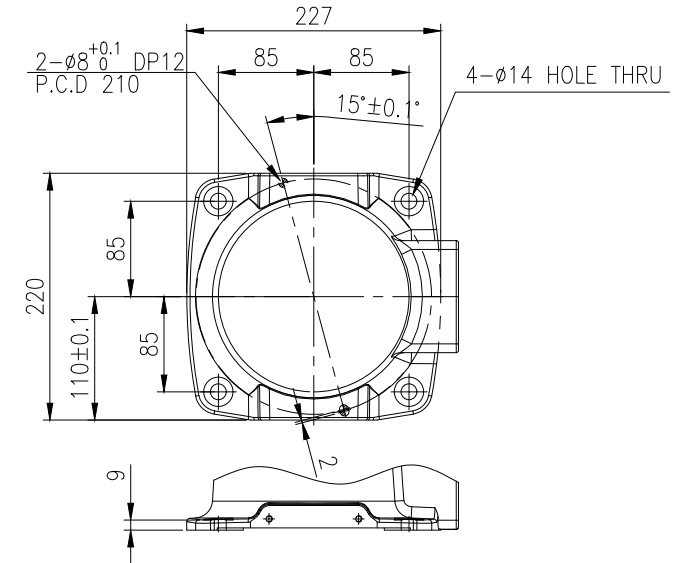
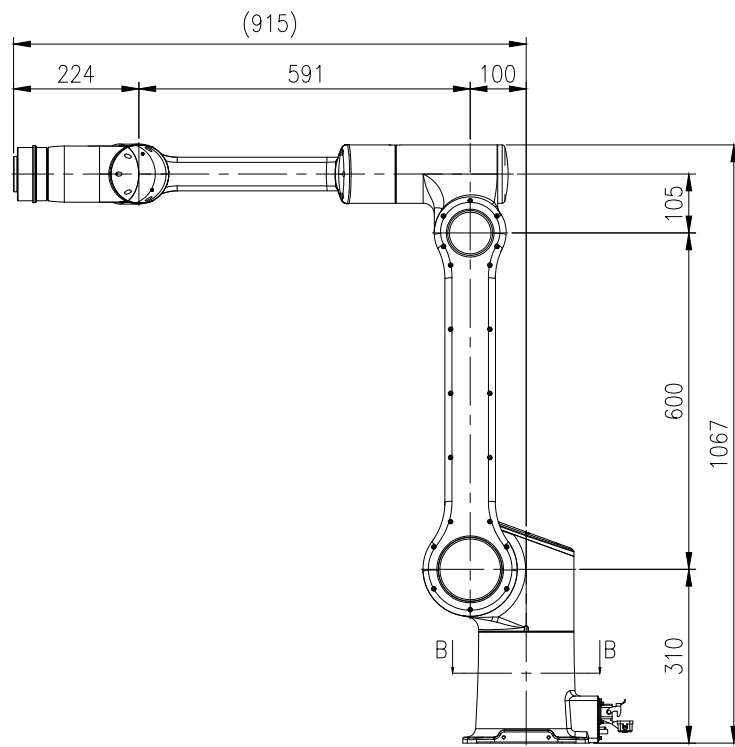
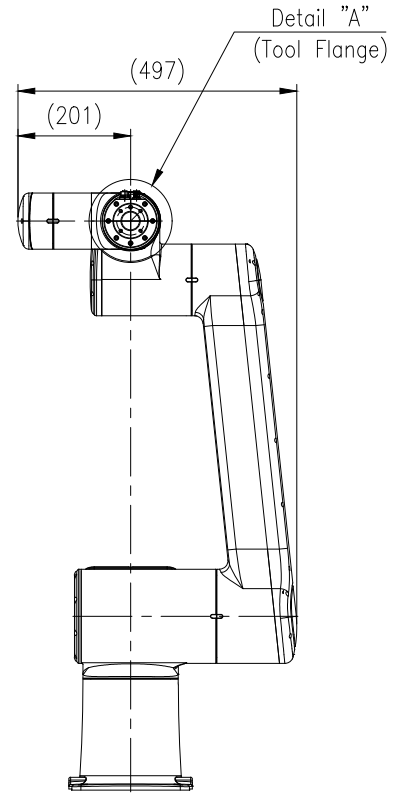

Section B-B (BASE MOUNT)
(Scale 1/2)

UNIT : mm



TEL : +82-70-7147-8888 WEB : robot_inquiry@hanwha.com			
TITLE	Body_HCR12_AREA_R00_2D		
RELEASED DATE	2019. 03. 27	Rev.	Sheet
DWG NO.	FC34-001238A	00	1/2

Unauthorized copying because it is Hanwha Precision Machinery Co., Ltd. owns, this article is strictly prohibited and open or to transfer to another person. A1(841X504)

번	일	년	월	일	년	월	일	년	월	일

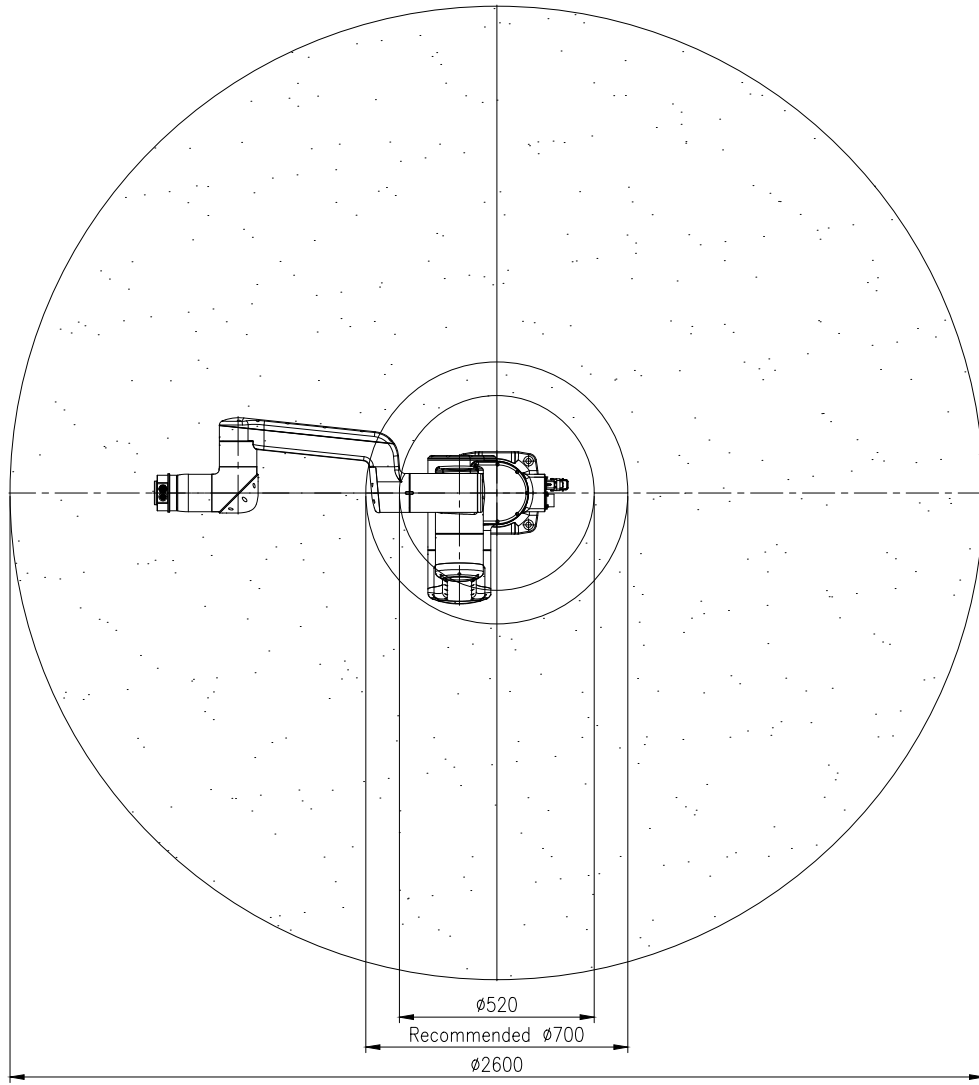

HCR-12 Working area, top view

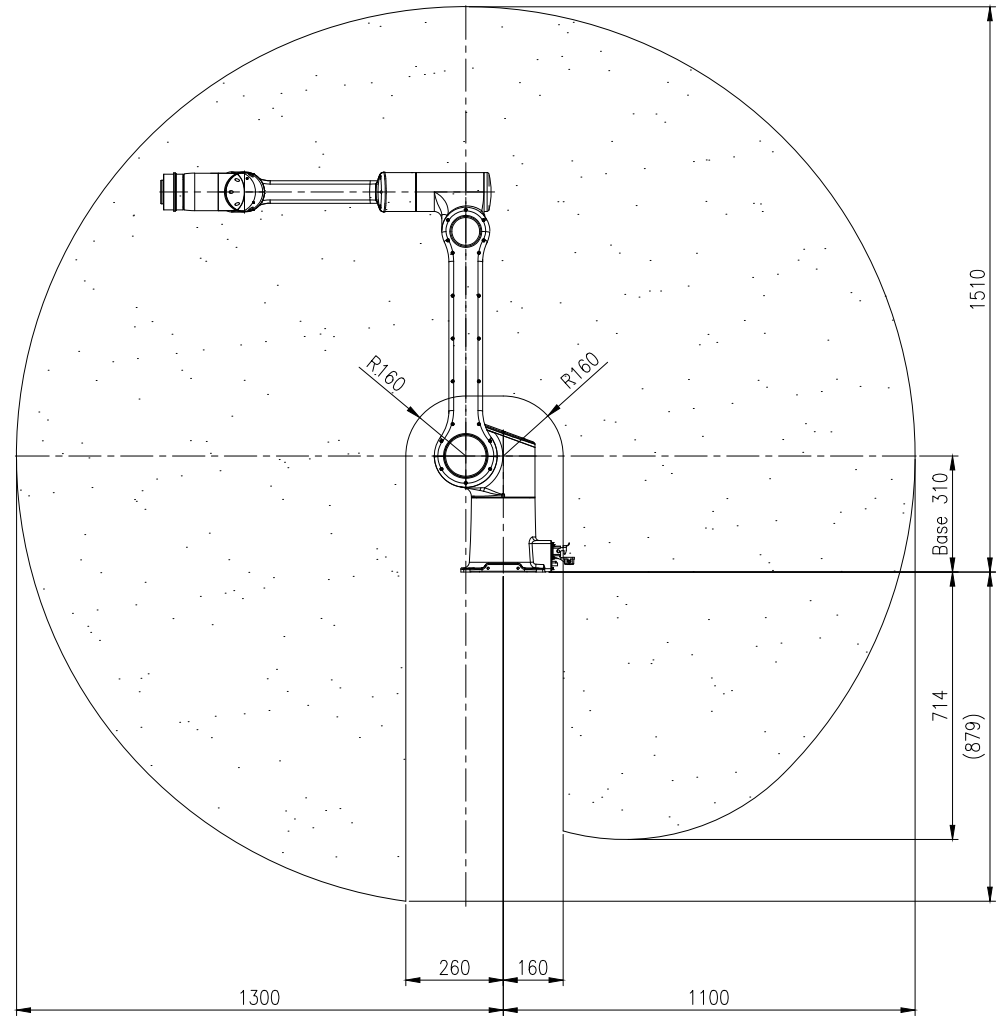

HCR-12 Working area, side view

UNIT : mm



TEL : +82-70-7147-8888 WEB : robot_inquiry@hanwha.com

TITLE	Body_HCR12_AREA_R00_2D		
RELEASED DATE	2019. 03. 27	Rev.	Sheet
DWG NO.	FC34-001238A	00	2/2

Unauthorized copying because it is Hanwha Precision Machinery Co., Ltd. owns, this article is strictly prohibited and open or to transfer to another person. A1(841X594)